

MACHINED RING NEEDLE ROLLER BEARINGS STAINLESS STEEL

WITH INNER RING



NA49..M, NKI..M TYPE

**STAINLESS
STEEL !!**

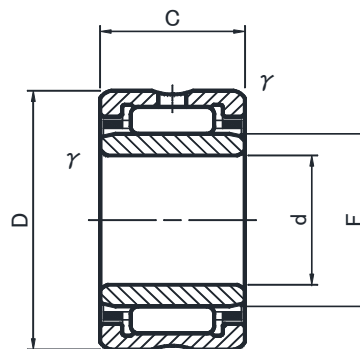

NA49...M, NKI...M

Shaft Diameter (mm)	Designation		Dimensions (mm)				Standard mounting dimensions (mm)			Basic dynamic load rating	Basic static load rating	Limiting speed	Weight
			D	C	1) γ s min	F	da		Da MAX				
d	NA49	NKI	D	C	1) γ s min	F	MIN	MAX	Da MAX	Cr N	Cor N	2) rpm	g
5	—	NKI 5/12M	15	12	0.3	8	7	7.7	13	4000	3700	32000	11.9
5	—	NKI 5/16M	15	16	0.3	8	7	7.7	13	5600	5800	32000	16.7
6	NA 496M	—	15	10	0.15	8	7.2	7.7	13.8	3100	2700	32000	9.1
6	—	NKI 6/12M	16	12	0.3	9	8	8.7	14	4400	4200	30000	13
6	—	NKI 6/16M	16	16	0.3	9	8	8.7	14	6000	6500	30000	17.5
7	NA 497M	—	17	10	0.15	9	8.2	8.7	15.8	3600	2800	30000	11.2
7	—	NKI 7/12M	17	12	0.3	10	9	9.7	15	4700	4800	28000	14.3
7	—	NKI 7/16M	17	16	0.3	10	9	9.7	15	6500	7300	28000	19.2
8	NA 498M	—	19	11	0.2	10	9.2	9.7	17.4	4900	4000	28000	15
9	—	NKI 9/12M	19	12	0.3	12	11	11.5	17	5200	5800	26000	16.7
9	—	NKI 9/16M	19	16	0.3	12	11	11.5	17	7300	8900	26000	22.5
9	NA 499M	—	20	11	0.3	12	11	11.5	18	5200	5000	26000	16.7
10	NA 4900M	—	22	13	0.3	14	12	13	20	7300	8000	24000	24
10	—	NKI 10/16M	22	16	0.3	14	12	13	20	9400	10900	24000	30
10	—	NKI 10/20M	22	20	0.3	14	12	13	20	11800	14800	24000	38
12	NA 4901M	—	24	13	0.3	16	14	15	22	7700	8800	23000	26.5
12	—	NKI 12/16M	24	16	0.3	16	14	15	22	9800	12000	23000	33.5
12	—	NKI 12/20M	24	20	0.3	16	14	15	22	12400	16300	23000	42.5
15	—	NKI 15/16M	27	16	0.3	19	17	18	25	11200	14900	21000	39.5
15	—	NKI 15/20M	27	20	0.3	19	17	18	25	14100	20200	21000	50
15	NA 4902M	—	28	13	0.3	20	17	19	26	8700	11000	20000	35
17	NA 4903M	—	30	13	0.3	22	19	21	28	9400	12400	18000	39
20	NA 4904M	—	37	17	0.3	25	22	24	35	16800	20000	16000	78.5
25	NA 4905M	—	42	17	0.3	30	27	29	40	18900	24500	13000	92.5

1) Smallest permissible chamfer dimension.

2) Suitable for oil lubrication. In case of grease lubrication, up to 60% of this value.

• NKI type of 8mm or less bore diameter (d) is without oil holes.

Oil hole on these small sizes is also available on request.



JNS CO., LTD.
NOSE SEIKO CO., LTD.